

# Z-Wave Garage Door Control (GDC-3)

## Introduction

GDC-3 is a Z-Wave Garage Door Control that connects to the garage door opener. After joining Z-Wave network, GDC-3 can receive commands from the Z-Wave network to activate connected garage door opener, providing convenient operation for remotely opening or closing the garage door.

GDC-3 also includes a wireless tilt sensor (Tilt-GDC3) that attaches to the inside of the garage door and reports the status of when the garage door is "open", "closed", or moving.

Before the remotely activated garage door begins to move, the warning LEDs on GDC-3 will flash and the built-in siren will emit alarm beeps.

Z-Wave is a wireless communication protocol that uses a low-power RF radio. The Z-Wave Garage Door Control allows access to the "S2 Unauthenticated" class and supports Z-Wave SmartStart inclusion as well as classic inclusion.

## Parts Identification

### GDC-3

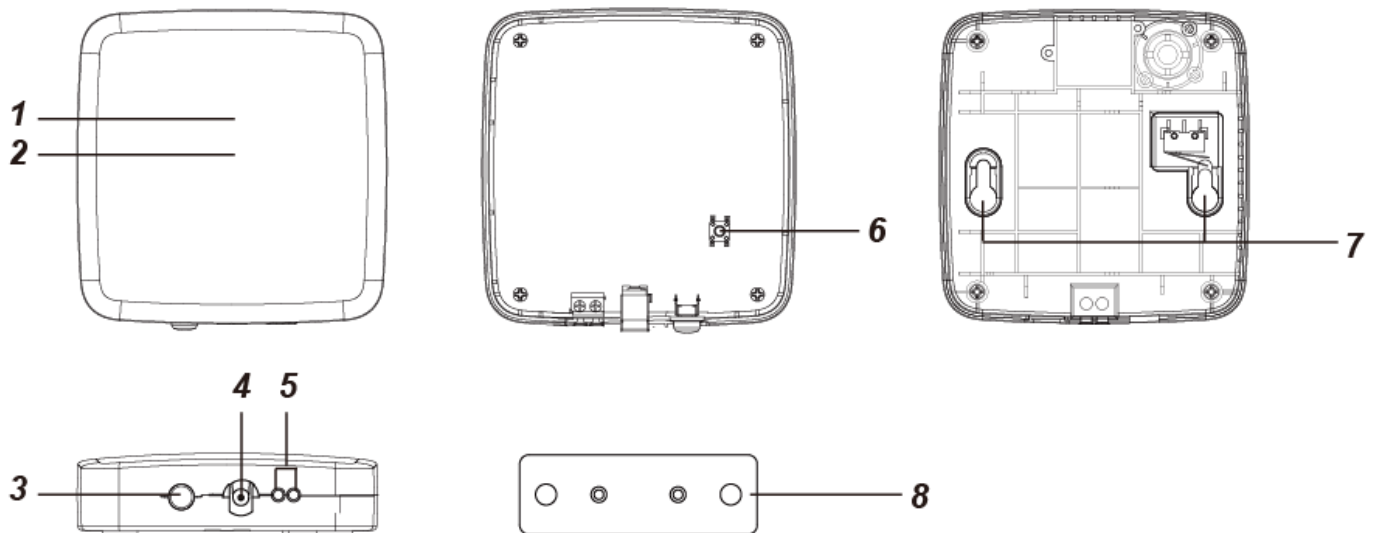

#### 1. Green LED indicator

- **On:** Connected to power supply.
- **Flashes with Red LED for 5 seconds:** Before the garage door moves.

#### 2. Red LED indicator

- **Flashes once every second:** In Learning Mode for Tilt-GDC3.
- **Flashes once every 5 seconds:** Tilt-GDC3 low on battery
- **Flashes with Green LED for 5 seconds:** Before the garage door moves.

#### 3. Function Button

- Press the button 3 times within 1 second to include or exclude the device in/from Z-Wave network.
- Press and hold the button for 10 seconds to factory reset.

#### 4. DC Jack

Connects to a DC 9V 1A output Power Adapter.

#### 5. Connection Terminals

Connect to the pushbutton wall console terminals on the garage door opener.

#### 6. Learn Button

Press the learn button once to enter learning mode for Tilt-GDC3.

#### 7. Mounting Holes

#### 8. Mounting Bracket

## Tilt-GDC3

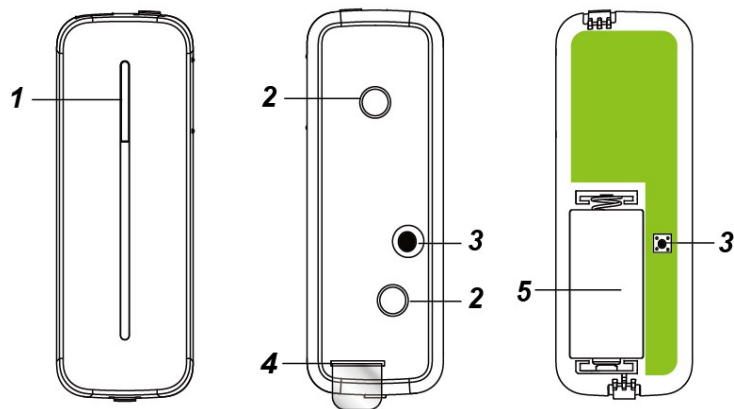

### 1. Test Button / LED Indicator

#### Test Button:

- Press the Test button to transmit a learning code to GDC-3.
- Press the Test button to report garage door position and enter test mode for 3 minutes. Under Test Mode, the LED will light up whenever the Garage Tilt Sensor is activated.

#### LED Indicator:

- The LED will flash for 3 times when it is transmitting a learning code.
- The LED will light up whenever the device is triggered under Test Mode.
- The LED will light up whenever the tamper switch is activated.
- (Door opened) When experiencing device fault or under Test Mode, the LED will flash for 6 times.
- (Door closed) When experiencing device fault or under Test Mode, the LED will flash for 6 times. After 10 seconds, the LED will flash for 3 times.
- When the battery is exhausted, the Garage Tilt Sensor will stop all function, the LED will flash every 4 seconds.

### 2. Mounting Holes

Used to fix and screw the Garage Tilt Sensor directly on the top of the garage door.

### 3. Tamper Switch

When the Garage Tilt Sensor is mounted, the Tamper Switch will be fully compressed against the wall. When the device cover is opened or when it is removed from the mounted surface, the Tamper Switch will be activated. The LED will flash for 6 times and send a tamper open signal to notify user(s) of this condition.

### 4. Battery Insulator

### 5. Battery Compartment

The Garage Tilt Sensor is powered by one CR123 3V Lithium battery. When the battery voltage is low, a low battery signal will be sent to the Control Panel to notify user(s) of this condition.

## Getting Started

### ● **Learn Tilt-GDC3 into GDC-3**

Pull out the battery insulator of Tilt-GDC3 to power on the device, and connect GDC-3 to power supply.

- Press the learn button of GDC-3 once to enter learning mode. The GDC-3 will emit one beep, and the red LED will begin to flash.
- Press the Test Button of the Garage Tilt Sensor to send a learning code, the LED will flash for 3 times.
- If learning is successful, GDC-3 will emit 2 beeps to indicate. If the Garage Tilt Sensor has already been added into the GDC-3, the GDC-3 will emit a Di-Do sound to alert the user.
- Press the learn button of GDC-3 once again to return to normal mode, the red LED will turn off. Alternatively, GDC-3 will exit learning mode automatically with 5 beeps after 1 minute of inactivity.

#### < NOTE >

- ☞ The Garage Door Control supports only one tilt sensor. If learning in a second Tilt-GDC3 into GDC-3, the old Tilt-GDC3 will be replaced by the newly learned Tilt-GDC3.

### ● **Adding GDC-3 into the System (Inclusion)**

The device supports both classic inclusion process and SmartStart inclusion process.

### **Classic Inclusion**

- Connect GDC-3 to power supply
- Put the Z-wave gateway or control panel into **Inclusion mode** (please refer to the Z-wave gateway or control panel manual).
- Within 1 second, press the Function Button 3 times.
- Refer to the operation manual of the Z-wave gateway or control panel to complete the adding process.
- If the Garage Door Control has already been added (included) into another Z-wave Gateway/Control Panel, or if it is unable to be added into the current Z-wave Gateway/Control Panel, try removing it first (see **Removing Device**).

### **SmartStart Inclusion**

SmartStart enabled products can be added into a Z-Wave network by scanning the Z-Wave QR Code present on the product with a controller providing SmartStart inclusion. No further action is required and the SmartStart product will be added automatically within 10 minutes of being powered on in the network vicinity. Z-Wave SmartStart utilizes the DSK of the device to enhance and simplify the inclusion process. **DSK** is Device Specific Key used for authentication and encrypted communication. The DSK information is stored in the QR code format that is printed on a label and adhered to the front side of the device, as example shown on the right hand side.

- Scan the QR Code on the back of GDC-3 to obtain **DSK** and transfer to the Z-Wave gateway.
- Connect GDC-3 to power supply, a SmartStart inclusion request will be automatically sent to the gateway.
- The gateway will automatically include the device upon recognition of the device by matching the inclusion request with the DSK obtained

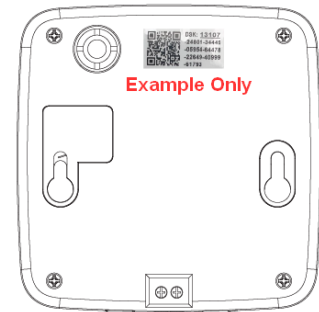

### **< NOTE >**

- ☞ The DSK of the device is used only during inclusion.
- ☞ The DSK can be read without the GDC-3 powering ON, so it is possible to prepare the gateway to include the device prior to installing and powering up the Garage Door Control.
- ☞ If the GDC-3 has already been **included** (learnt) into another Z-Wave Gateway/Control Panel, please exclude it first (see **Exclusion**) before attempting to **include** it into the current Z-Wave Gateway/Control Panel. The GDC-3 will not send a SmartStart inclusion request if it's already in a Z-Wave Gateway/Control Panel.

## ● ***Removing GDC-3 from the System (Exclusion)***

The Garage Door Control must be removed from existing Z-wave network before being added into another.

### **Exclusion Mode**

- Put the Z-wave gateway or control panel into **Exclusion mode** (please refer to the Z-wave gateway or control panel manual).
- Within 1 second, press the Function Button 3 times, and the device will be removed from the Z-wave network.

### **Factory Reset**

*(Only use factory reset when network Control Panel/Gateway is missing or inoperable).*

Factory resetting the device will restore it to factory default settings (i.e. not included into any Z-wave network).

- Press and hold the Function Button of the device for 10 seconds to perform factory reset.

### **< NOTE >**

- ☞ Before you remove or factory reset the GDC-3, please ensure that the device DSK information has been removed or does not exist in the gateway. If you remove or factory reset the device, but its DSK still exists in the gateway, the gateway will automatically include the device again.

## ● ***Range Test***

To test whether the Garage Door Control is able to communicate with the Z-Wave gateway or control panel:

- Put the gateway / panel into range test mode (Walk Test).
- Press the Function Button on the device.
- The gateway / panel should display if the device is within the operation range (please refer to the operation manual of the gateway / panel).

## **Installation**

### **Mounting the Tilt Sensor**

- The Garage Tilt Sensor is designed to be mounted on overhead garage door, not to be used on roll up garage door.
- The device shall be mounted vertically with the ground (It should not be tilted greater than +-5 degrees when mounted).
- Mount the device on a dry and clean surface. Ensure the device is mounted with the LED indicator on top.
- The Garage Tilt Sensor should be mounted on the top panel of the garage door, as shown below.

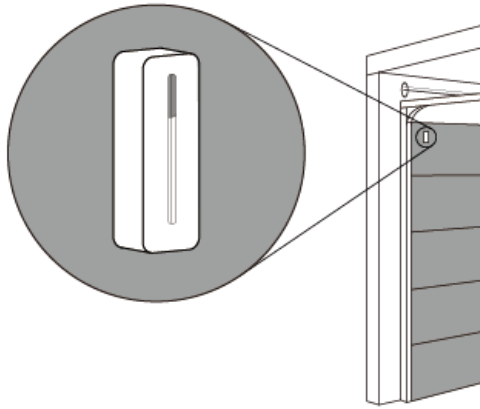

- There are two ways to mount the Garage Tilt Sensor.

**Screw Mounting**

1. Find a suitable location to install the Garage Tilt Sensor. The mounting surface should be clean and dry. Clean the mounting surface thoroughly if needed.
2. Use the two mounting holes as a template to mark and drill mounting holes.
3. Use the provided wall plugs for plaster/brick installation. Screw the Garage Tilt Sensor into the provided wall plugs. Ensure the wall plugs are flush with the wall.

**< NOTE >**

- ☞ Only use this type of mounting method when the garage doors are thicker than the screws.

**Adhesive Mounting:**

1. Find a suitable location to install the Garage Tilt Sensor. The mounting surface should be clean and dry. Clean the mounting surface thoroughly if needed.
2. Remove the protective covering from one side of the double-sided adhesive pad. Apply it to the back of the Garage Tilt Sensor and press firmly for 30 seconds to ensure good contact.
3. Remove the other side of the adhesive tape and firmly press the Garage Tilt Sensor onto a desired location for another 30 seconds. Please avoid applying the adhesive pad on uneven surface or re-applying it.

**Mounting the Garage Door Control**

- The Garage Door Control is usually mounted on the ceiling near the garage door opener and the power outlet.

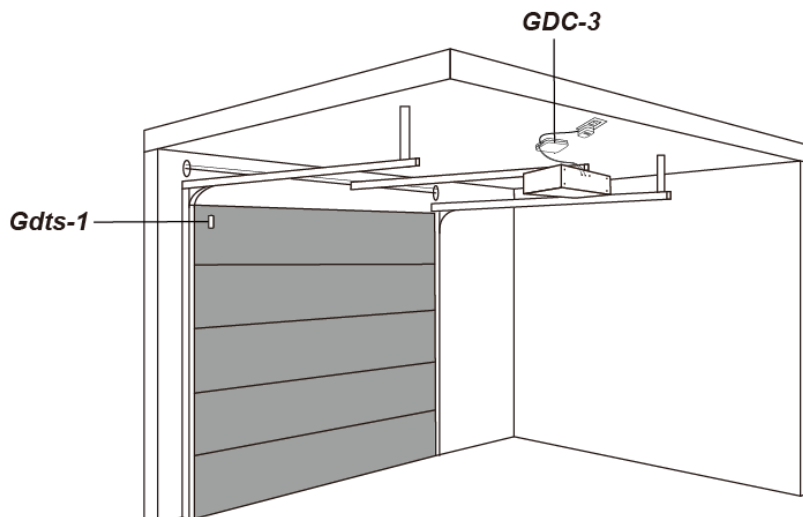

**WARNING :**

1. Before installation, ensure to disconnect power supply from the garage door opener.
2. The GDC-3 Garage Door Control must be installed in sight of the garage door, where both visual and audible alerts can be clearly seen and heard.

1. Using the mounting bracket as template, mark the two mounting holes, drill holes in mounting location and insert wall plugs if needed.
2. Screw the mounting bracket into marked location with the two hooks facing downward.

3. Hook the Garage Door Control onto the Wall Mounting Bracket (with the Mounting Holes of the Garage Door Control).
4. Push the Garage Door Control (in the direction as indicated in below picture) to lock it into the mounting bracket.

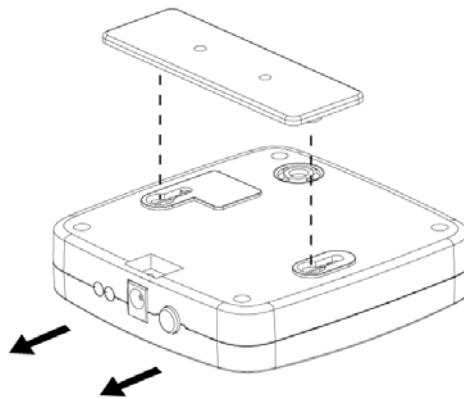

5. Connect the GDC-3 terminals to the pushbutton wall console terminals on the garage door opener. (Either wire can be connected to either terminal. (The wall console terminals may be named "PWC", "WC", "PB", "PUSHBUTTON" or "RED" and "WHITE". Terminal names and locations vary by model.)
6. Plug in the DC 9V 1A output Power Adapter and connect to power supply.
7. Restore power to your garage door opener.

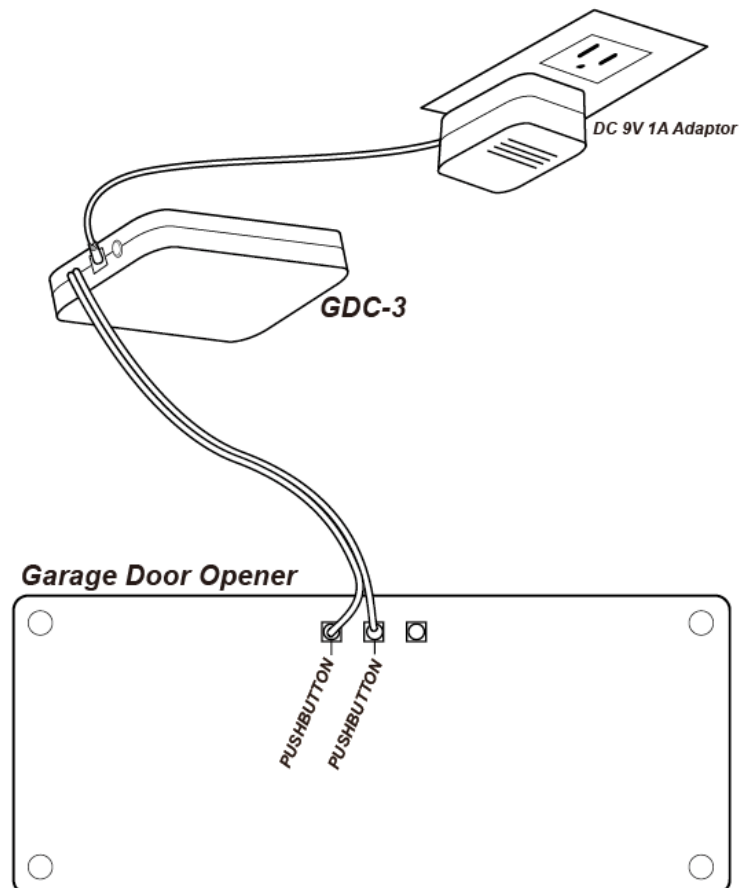

## Operation

### ● Remote Operation of Garage Door

- After GDC-3 has been included in the Z-Wave network, the Z-Wave controller can remotely open or close the garage door with Z-Wave command [COMMAND\_CLASS\_BARRIER\_OPERATOR] and [BARRIER\_OPERATOR\_SET], using parameters below:
  - Open : Target Value = 0xFF
  - Close : Target Value = 0x00
- Before the remotely activated garage door begins to move, the warning LED indicators (Green and Red) will

flash and alarm beeps will sound for 5 seconds. As the garage door starts moving, the garage door's position) will be reported to the Z-Wave controller.

[COMMAND\_CLASS\_BARRIER\_OPERATOR] [BARRIER\_OPERATOR\_REPORT]

State:

- BARRIER\_OPERATOR\_CLOSED 0x00
- BARRIER\_OPERATOR\_CLOSEING 0xFC
- BARRIER\_OPERATOR\_STOPPED 0xFD
- BARRIER\_OPERATOR\_OPENING 0xFE
- BARRIER\_OPERATOR\_OPEN 0xFF

- Once GDC-3 starts the movement of the garage door, another command cannot be sent for 35 seconds. If a second command is sent within 35 seconds, GDC-3 will return busy signal to the Z-Wave controller.

[COMMAND\_CLASS\_APPLICATION\_STATUS] [APPLICATION\_BUSY]

- Status : 0x00
- Wait Time : 0x00

- When the garage door is in open status, GDC-3 will bypass any open command from the Z-Wave Controller. When the garage door is in closed status, GDC-3 will bypass any close command from the Z-Wave Controller.

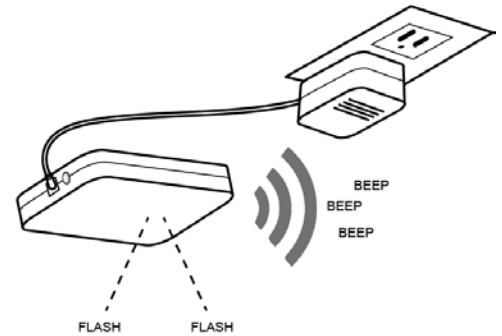

### ● Alarm Sound Volume

- Before the remotely activated garage door begins to move, the warning LED indicators will flash and alarm beeps will sound for 5 seconds. Users can adjust the alarm sound volume by sending command from the Z-Wave Controller with Configuration CC command, using parameters below:

- S : Size
- D : Default

Num	Name	S	Min	Max	D	Description
1	Alarm sound level	1	0	2	2	0:silent 1:small 2:loud

### ● Garage Door Tilt Sensor (Tilt-GDC3) Features

#### ● Garage Door Position Detection

Whenever the garage door position changes, Tilt-GDC3 will report the door's position to GDC-3, and GDC-3 will report to the Z-Wave controller with Z-Wave command [COMMAND\_CLASS\_BARRIER\_OPERATOR] [BARRIER\_OPERATOR\_REPORT].

- BARRIER\_OPERATOR\_CLOSED 0x00
- BARRIER\_OPERATOR\_CLOSEING 0xFC
- BARRIER\_OPERATOR\_STOPPED 0xFD
- BARRIER\_OPERATOR\_OPENING 0xFE
- BARRIER\_OPERATOR\_OPEN 0xFF

#### ● Tamper Protection

The Tilt Sensor Tilt-GDC3 is protected by a tamper switch when it is mounted flush against the mounting surface. When the device is removed from the mounting surface or when the device cover is opened, its tamper switch will be activated. The device will then send a tamper open signal to GDC-3, and GDC-3 will report to the Z-Wave controller with Z-Wave command [COMMAND\_CLASS\_NOTIFICATION] [NOTIFICATION\_REPORT]

- Open: 00 00 00 FF 07 03 00 00
- Close: 00 00 00 FF 07 00 01 03

#### ● Supervisory Signal

The Tilt Sensor Tilt-GDC3 will transmit Supervisory Signal along with the garage door's position to GDC-3 every 15-20 minutes. GDC-3 will report to the Z-Wave controller using [BARRIER\_OPERATOR\_REPORT].

If the Z-Wave controller fails to receive any supervisory signals of the Tilt Sensor over a preset period of time, an "Out-Of-Order" fault message will be generated.

- Supervision error: 00 00 00 FF 06 49 00
- Restore: 00 00 00 FF 06 00 00 (Both the battery status and supervision signal need to be back to normal)

#### ● Low Battery

The Tilt Sensor Tilt-GDC3 features Low Battery Detection function. When the battery voltage is low, the Tilt Sensor will transmit Low Battery signal to GDC-3, and GDC-3 will report to the Z-Wave controller with Z-Wave command [COMMAND\_CLASS\_NOTIFICATION] [NOTIFICATION\_REPORT].

- Low Battery: 00 00 00 FF 06 4A 00
- Restore: 00 00 00 FF 06 00 00 (Both the battery status and supervision signal need to be back to normal)

## Z-Wave Information

**Device Type:** GENERIC\_TYPE\_ENTRY\_CONTROL  
**Specific Type:** SPECIFIC\_TYPE\_SECURE\_BARRIER\_ADDON  
**Icon Type:** ICON\_TYPE\_GENERIC\_BARRIER  
**Role Type:** Always On Slave (AOS)  
**Security:** S2\_UNAUTHENTICATED  
**Manufacturer ID:** 0x018E  
**Product Type ID:** 0x0004  
**Product ID:** 0x0127

### ● Supported Command Class

Command Class	Version	Required Security Class
Association	2	Highest Granted Security Class
Association Group Info	3	Highest Granted Security Class
Basic	2	Highest Granted Security Class
Device Reset Locally	1	Highest Granted Security Class
Firmware Update Meta Data	5	Highest Granted Security Class
Manufacture Specific	2	Highest Granted Security Class
Multi Channel	4	Highest Granted Security Class
Multi Channel Association	3	Highest Granted Security Class
Power level	1	Highest Granted Security Class
Configuration	1	Highest Granted Security Class
Notification	8	Highest Granted Security Class
Barrier Operator	1	Highest Granted Security Class
Application Status	1	Highest Granted Security Class
Version	3	Highest Granted Security Class
Transport Service	2	None
Z-Wave Plus Info	2	None
Security 2	1	None
Supervision	1	None

### ● Association Groups

ID	Name	Max Node	Description
1	Lifeline	5	Supports the following command classes: <ul style="list-style-type: none"> <li>• Notification report: triggered from tamper, low battery, supervision error.</li> <li>• Barrier Operator report: GDC open/close.</li> <li>• Application busy report: triggered from Barrier Operator Set within 35 secs.</li> <li>• Device Reset Locally: triggered upon reset</li> </ul>